



**Product Features**

-  Certified to EN 1433 Load Class A 15(kN) which is similar to AS 3996 Load Class A (10kN) (NATA endorsed load test reports available)
-  AS 1428.2 (Clause 9c) compliant for wheelchair and walking cane safety
-  AS 3996 (Clause 3.3.6) compliant for bicycle tyre penetration resistance
- **QuickLok** boltless locking system
- Suitable for use with K100, KS100, H100K, H100KS channels
- Manufactured from either galvanised steel or Grade 304 stainless steel (pictured)
- Galvanised steel for use in general purpose applications
- Stainless steel used for aesthetics and/or its corrosion resistant properties

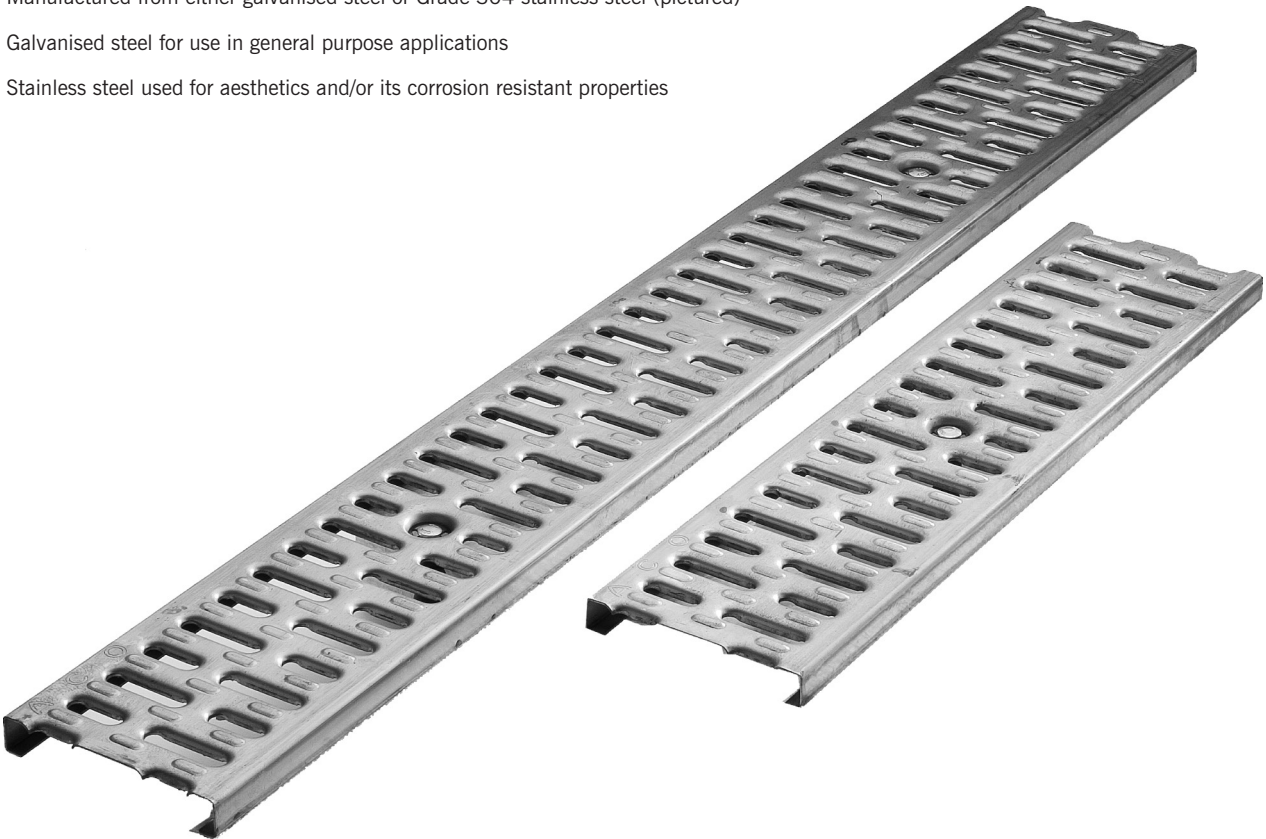

**Specifications**

The grate shall be ACO Type 420Q/450Q\* Galvanised/Stainless\* Slotted grate with **QuickLok** boltless locking system as manufactured by ACO. This grate has an overall width of 123mm and overall length of 1000mm (Type 420Q/450Q\*) and 500mm (Type 421Q/452Q\*). Slot widths measure at a maximum of 10mm.

**Materials & Design**

The grate shall be manufactured from galvanised/stainless\* steel and have **minimum** properties and characteristics as follows:

- Manufactured from galvanised/Grade 304 stainless\* steel
- Certified to EN 1433 Load Class A 15(kN)<sup>1</sup> which is similar to AS 3996 Load Class A (10kN)
- Meets AS 1428.2 (Clause 9c); AS 3996 (Clause 3.3.6)
- Intake area of 24,380mm<sup>2</sup> per metre of grate/12,190mm<sup>2</sup> per half metre of grate

<sup>1</sup> NATA endorsed test reports available

For the specification of the ACO Drain channel system selected, click: <http://www.acodrain.com.au/resource>

\* delete as appropriate

ACO Specification Information

**ACO DRAIN®**

**Type 420Q/421Q/450Q/452Q Steel Slotted grate**

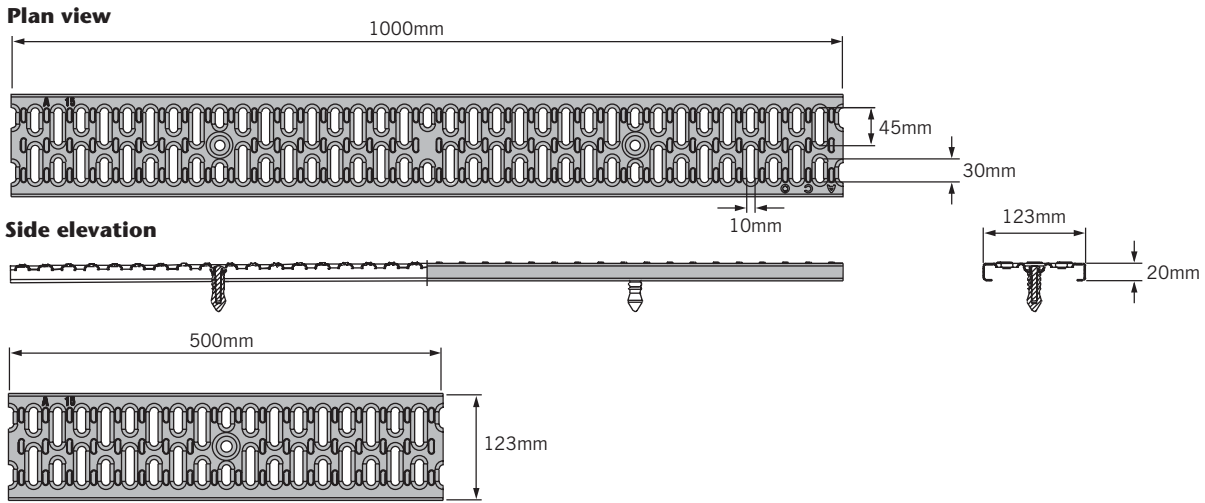

Description	Part No.	Length (mm)	Width (mm)	Weight (kg)
<b>QuickLok grate</b>				
Type 420Q Galvanised Slotted	<b>31530</b>	1000	123	2.7
Type 421Q Galvanised Slotted	<b>31531</b>	500	123	1.4
Type 450Q Stainless Slotted	<b>31630</b>	1000	123	2.7
Type 452Q Stainless Slotted	<b>31631</b>	500	123	1.4
<b>QuickLok locking bar</b>	<b>02899</b>	-	-	0.1
Grate removal tool	<b>01318</b>	-	-	0.1

**QuickLok locking mechanism**

ACO **QuickLok** is a patented boltless locking system, grates are removed and replaced with the minimum time and effort for ease of maintenance. The unique design provides a positive 'snap down' fit into the locking bar. A spigot is fixed to the grate which 'locks' into the spring in the locking bar.

The **QuickLok** spigot is manufactured from stainless steel and high density nylon, the locking bar and spring are stainless steel, for use in both general purpose and corrosive environments.

- Channel
- Grate
- QuickLok** locking spigot (fixed to grate)
- QuickLok** locking spring (fixed to locking bar)
- QuickLok** locking bar (side and plan views)

**ACO Polycrete Pty Ltd**  
**Australia**  
 Ph: 1300 765 226  
 www.acodrain.com.au  
 sales@acoaus.com.au

**ACO Limited**  
**New Zealand**  
 Ph: 0800 448 080  
 www.acodrain.co.nz  
 sales@aconz.co.nz



© March, 2014 ACO Polycrete Pty Ltd. All reasonable care has been taken in compiling the information in this document. All recommendations and suggestions on the use of ACO products are made without guarantee since the conditions of use are beyond the control of the company. It is the customer's responsibility to ensure that each product is fit for its intended purpose and that the actual conditions are suitable. ACO Polycrete Pty Ltd. pursues a policy of continuous product development and reserves the right to amend specifications without notice.